

# Single Family Detached Garage

## Building Guide

---

561 E. Garden Dr Unit C / Windsor, CO 80550 / Phone: (970) 686-7511 / Fax: (970) 686-9248

The purpose of this guide is to assist you in the permit process for your project. This handout is intended as a basic plan submittal under the 2006 International Residential Code. It is not intended to cover all circumstances. Depending on the scope and complexity of your project, additional and/or more detailed plans might be required.

### How to Use this Guide:

**1. Complete this Building Guide**

Fill in the blanks on page two (2) and indicate which construction details will be used. At least two completed copies must be provided to apply for a building permit.

**2. Provide two (2) plot plans:**

Show the dimensions of your project and its relationship to existing setbacks, easements, structures on the property, and the distance to property lines. All property pins must be located. If proposed structure is less than 12" from the minimum setback required by your local zoning ordinance an as-built survey is required. Locations of any easements are the responsibility of the property owner. Structures shall not be located on easements.

**3. Submit a completed Permit Application:**

Applications may be obtained at the jurisdiction. It is important that the permit is filled out completely to the best of your knowledge and that you provide any additional pertinent information.



# CONSTRUCTION DETAILS

## Single Family Detached Garage

### Directions

1. Fill in the blanks on page 2 and 3 with dimensions and materials which will be used to build the structure. Please print legibly.
2. Indicate in the check boxes on page 3 which detail from 4 will be used.

**Job Site Address:** \_\_\_\_\_  
\_\_\_\_\_

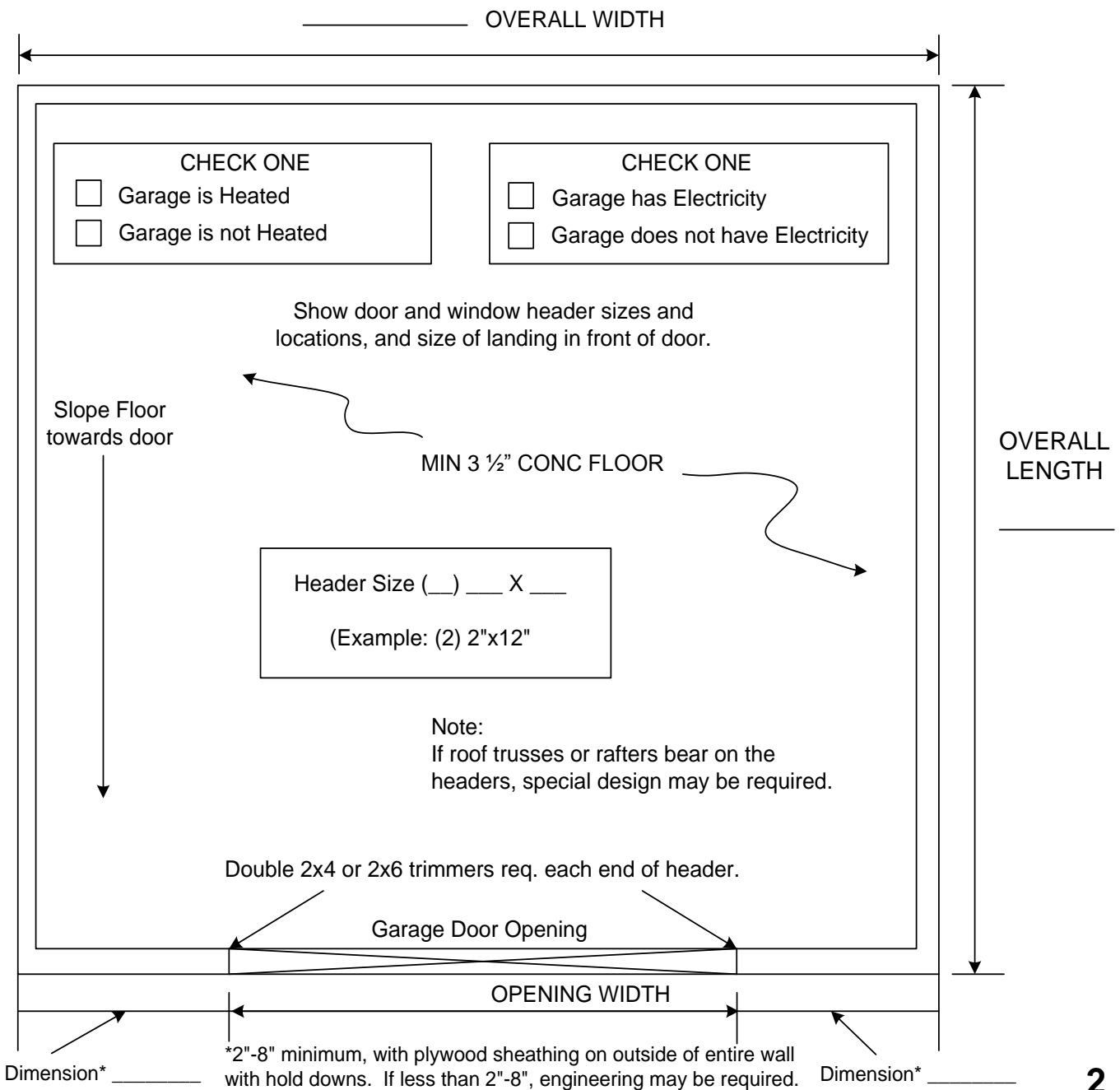

# CONSTRUCTION DETAILS

## Single Family Detached Garage

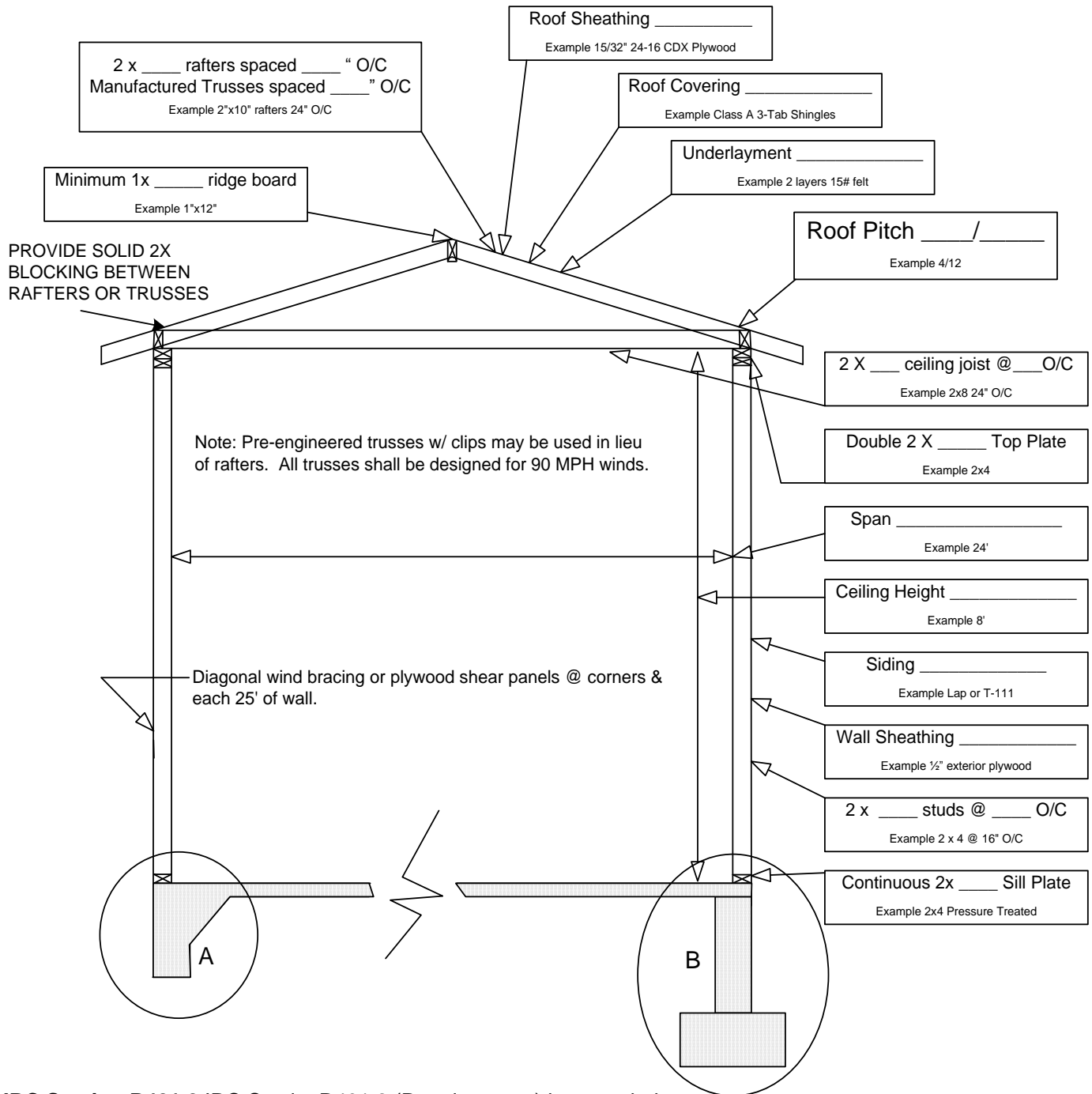

**IRC Section R401.2** IRC Section R401.2 (Requirements) is amended by the addition of the following:

Foundations shall be designed and the construction drawings stamped by a Colorado registered professional engineer or licensed architect. The drawings must be noted with the engineering firm name, specific location for design and soils report number if applicable. See Building Department for further information.

# CONSTRUCTION DETAILS

## Single Family Detached Garage

### FOUNDATION DETAIL A

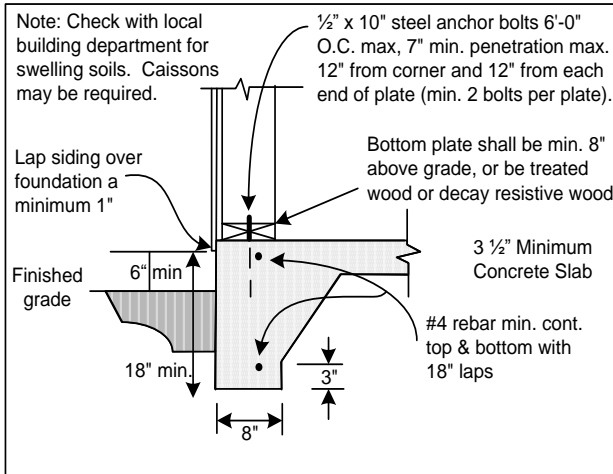

### FOUNDATION DETAIL B

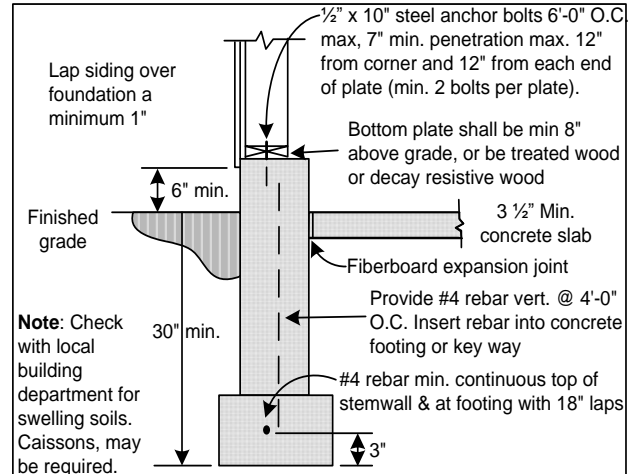

### BRACED WALL PANEL DETAIL

